

Deflection and Stress Analysis of Sandwich Plate under Uniformly Distributed Load using FSDT

Pranav Vishwakarma¹, Dr. Rajesh Kumar Satankar²

¹Post Graduate Student, Department of Mechanical Engineering, Jabalpur Engineering Collage 482011, India

²Associate Professor, Department of Mechanical Engineering, Jabalpur Engineering collage 482011, India

Abstract: The deflection and stress values of sandwich plate with uniformly distributed load (UDL) are investigated. The sandwich structure is modeled using the First order shear deformation theory for the mathematical purpose. The analysis of deflection and stress values is done in ANSYS 18.0 software. Lastly, the influences of structural parameters (Face to core thickness ratio, aspect ratio, thickness ratio, boundary conditions) the deflection and stress values are obtained, and for subsequent conclusions discuss accordingly.

Keywords: Deflection and stress analysis, sandwich plate, First order shear deformation theory.

1. Introduction

Composite and sandwich plates are widely used in aerospace, marine, defense equipment, automobile etc. The growing work of sandwich structure because light weight, high strength, low cost, and other advantages such as fire resistance, extreme load bearing capacity, and damping characteristics. The use of these characteristics it is necessary to build appropriate model, which is capable to predicting their structure. The free vibration is done by using classical analytical theory [1-3], Finite element analysis using First order and higher order shear deformation theories [4-7]. In these studies, the core of sandwich plate assumed incompressible. But this is true only for honeycomb core. In case of a flexible sandwich core this assumption is prevent. The higher order shear deformation theory [8] is use to derive the mathematical model and show the behavior of plates with flexible core.

The first order shear deformation theory the accuracy of solution is based on shear correction factors. This limitation is reduced by higher order theory, finite element method is also proposed by using of Reddy's higher order theories. Comparison of the first order and higher order, the higher order theory is more accurate in calculating frequencies of plate [9-10]. But after same time more research ahead it is found that global higher order theory overestimate natural frequency for sandwich plate with different thickness and material. To vanquish the drawback of global higher order theory, the layer wise theory is more accurate to calculate frequency of sandwich structure. In other hand some of theory is also present such as Zig – Zag theory in Kapuria et al [11] which is assess the effort of laminated and sandwich plate.

For the review of articles this present work is based on First order shear deformation theory. In the present work deflection and stress of sandwich plate is calculated and compare the results of different boundary conditions.

Plate Geometry:

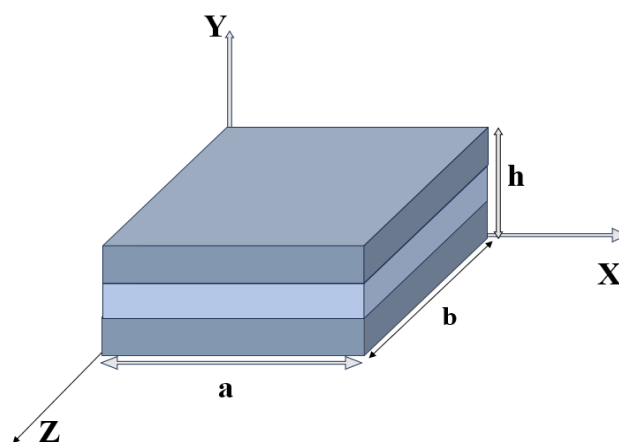

Figure 1: Sandwich plate a and b, Lenth and width of sandwich plate, h is total thickness of plate in which three layer first and last is Face layer and middle one is Core layer.

$$h = 2t_f + t_c$$

t_f = thickness of Face

t_c = thickness of Core

2. Methodology

The First order shear deformation theory is basic concept of structural engineering and mechanics. The First order shear deformation theory also called the Mindlin-Reissner theory. It is use to analyze the structural behavior of thin wall and plate. In this theory the shear deformation is important for study. It assumes that the transverse shear strain is linearly varying across the thickness of plate.

Some of assumption is also consider the axial and transverse normal strains and rotations components.

The displacement felid is:

$$u_x(x, y, z) = u_{x0}(x, y) + \phi_x(x, y)z$$

$$u_y(x, y, z) = u_{y0}(x, y) + \phi_y(x, y)z$$

$$u_z(x, y, z) = u_{z0}(x, y)$$

The quantities (u_{x0} , u_{y0} , u_{z0} , ϕ_x , ϕ_y) all are unknowns.

3. Model Analysis of Plate

The sandwich plate is made of three-layer two face layer and middle layer is called core layer. The dimension of the plate is depending on ratio of t_c/t_f , and the aspect ratio is 1. The thickness ratio a/h is also change such as (10,20,30,40,50) and t_c/t_f ratio is 0,1,3,5. The deflection is carried out under UDL. And the plate is made in ANSYS 18.0.

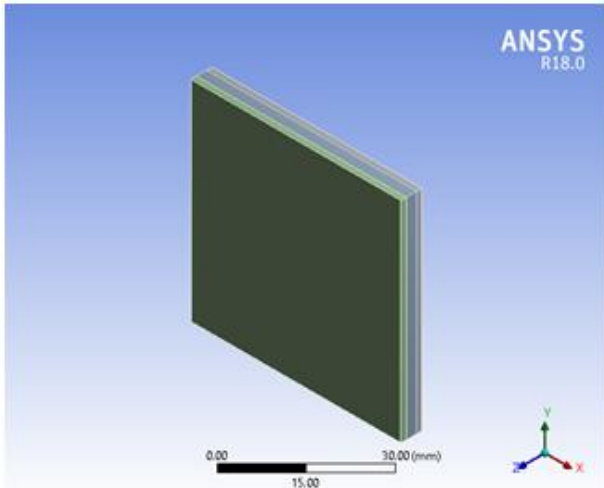

Figure 2: Geometry of plate

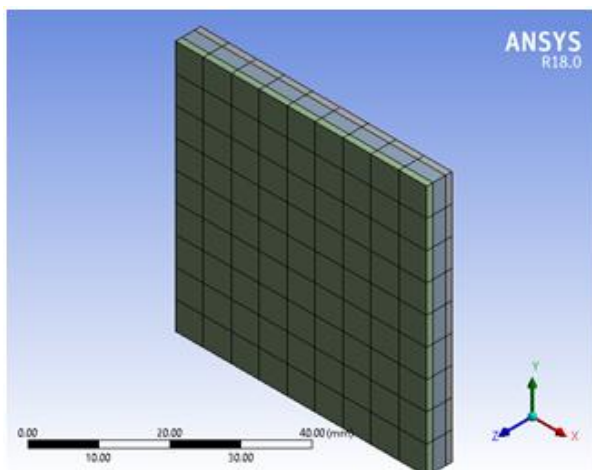

Figure 3: Generation of mesh

4. Results and Discussion

In this article, the deflection and corresponding stress is calculated in the sandwich plate. The material of plate layer is

Table 1: Material property

Material properties	
Aluminum (Face layer)	
Density (kg/m^3)	2700 kg/m^3
Young's modulus E	72×10^9 Pa
Poisson's ratio	0.3
Viscoelastic material (Core layer)	
Density (kg/m^3)	1140 kg/m^3
Young's modulus E	1×10^6 Pa
Poisson's ratio	0.49

Table 2: Deflection and stress analysis to change thickness ratio and also change the t_c/t_f ratio, with All side is clamp.

Maximum Deformation

Thickness Ratio	$t_c/t_f = 0$	1	3	5
10	4.10E-04	0.0137	0.0928	0.28704
20	0.0015	0.0474	0.3467	0.9602
30	0.0034	0.1053	0.70602	1.6572
40	0.0061	0.184	1.1033	2.2184
50	0.0095	0.2797	1.4858	2.6285

Maximum Stress

Thickness Ratio	$t_c/t_f = 0$	1	3	5
10	0.7374	7.1063	23.908	49.104
20	0.7456	5.9389	21.733	42.815
30	0.8778	6.8578	23.854	40.646
40	0.9605	7.3975	23.96	37.3
50	1.0049	7.5959	22.82	33.15

Table 3: Deflection and stress analysis to change thickness ratio and also change the t_c/t_f ratio, with two side clamps

Maximum Deformation

Thickness Ratio	$t_c/t_f = 0$	1	3	5
10	0.000951	0.031178	0.21879	0.66107
20	0.003569	0.10934	0.77096	1.9977
30	0.007953	0.2398	1.5025	3.2205
40	0.014112	0.41336	2.2497	4.1147
50	0.02202	0.62075	2.9244	4.7436

Maximum Stress

Thickness Ratio	$t_c/t_f = 0$	1	3	5
10	1.3972	12.004	42.461	86.934
20	1.5852	13.329	47.6	85.517
30	1.751	14.412	47.685	76.051
40	1.821	14.682	44.656	65.887
50	1.8449	14.486	40.632	57.017

Table 4: Deflection and stress analysis to change thickness ratio and also change the t_c/t_f ratio, with one side clamps

Maximum Deformation

Thickness Ratio	$t_c/t_f = 0$	1	3	5
10	0.0389	1.1464	6.4616	12.449
20	0.1558	3.8503	13.388	19.177
30	0.3504	6.864	17.509	22.566
40	0.6237	9.5646	20.302	24.901
50	0.9751	11.893	22.487	26.838

Maximum Stress

Thickness Ratio	$t_c/t_f = 0$	1	3	5
10	10.026	80.422	253.47	394.13
20	11.166	75.729	193.22	274.16
30	11.586	68.887	155.57	211.57
40	11.827	62.163	131.53	175.07
50	11.955	56.466	114.47	150.19

Corresponding graph of table 2:

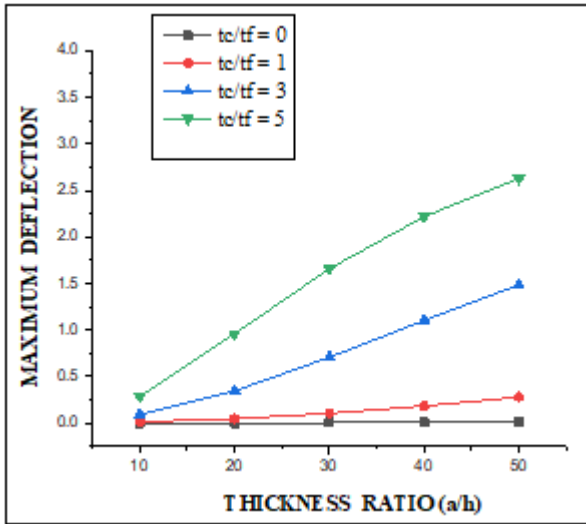

Figure 4: Under UDL development of deflection in all side Clamp

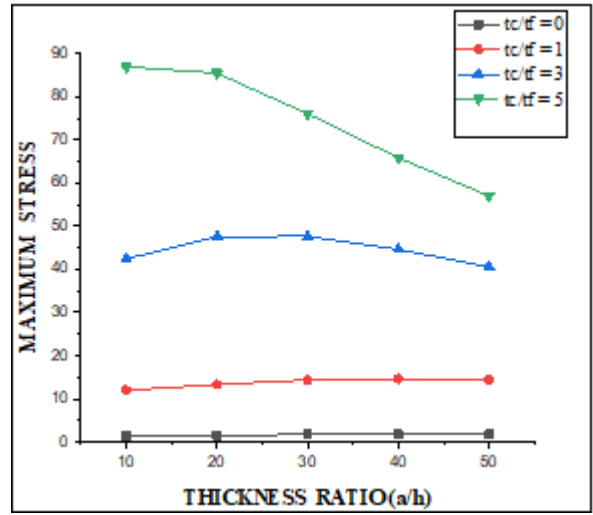

Figure 7: Under UDL development of Stress shown.

Corresponding graph of table 4:

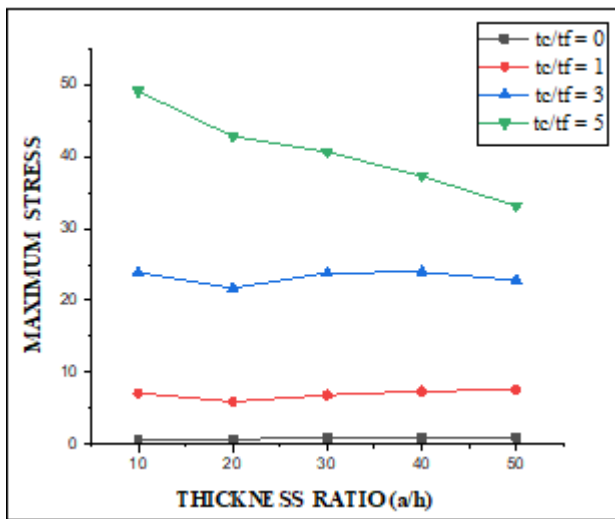

Figure 5: Under UDL development of Stress shown

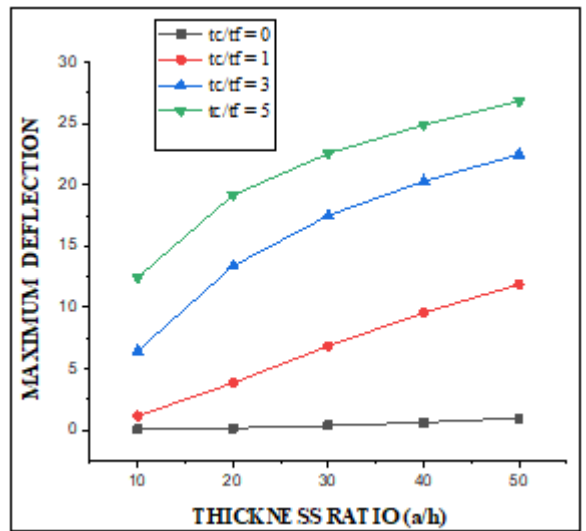

Figure 8: Under UDL development of deflection in one side Clamp

Corresponding graph of table 3:

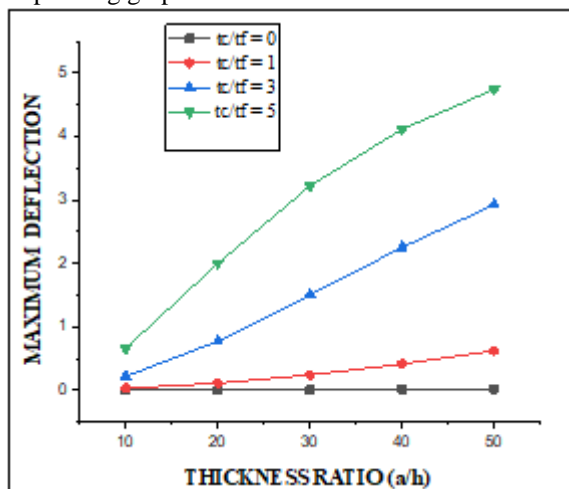

Figure 6: Under UDL development of deflection in two side Clamp

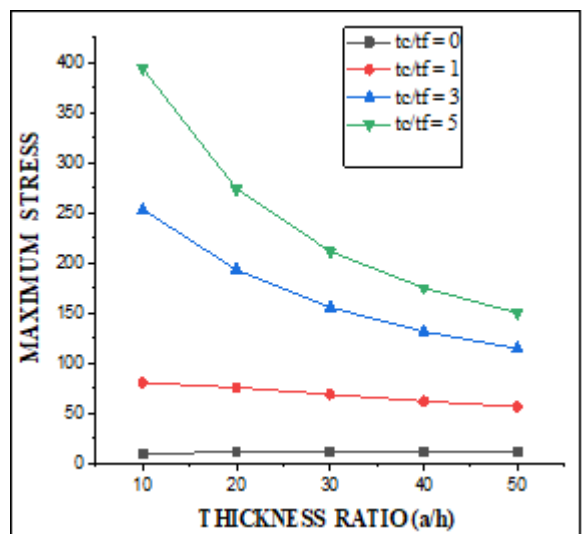

Figure 9: Under UDL development of Stress shown.

5. Conclusion

In this work it is proposed a layer wise plate to calculate the maximum deflection and maximum stress with soft core material. The implicit conclusions from the analysis are discussed in the following lines.

- From the analysis, it is observed that when applying the UDL, deflection is depending on both the ratios such as Thickness ratio (a/h) and t_c/t_f ratio.
- When increasing the thickness ratio with t_c/t_f ratio the deflection of plate is increasing and in stress analysis, the effect of stress is also depending on both ratios that is increasing as deflection.
- Also, the effect of boundary condition is observed in analysis, comparison of different boundary condition such as all side clamp (CCCC), Two side clamp (CFCF), One side clamp (CFFF) the value of deflection and stress is minimum in CCCC boundary condition.

References

- [1] Allen HG. Analysis and design of structural sandwich panels. London: Pergamon Press; 1966.
- [2] Vinson JR. The behavior of sandwich structures of isotropic and composite materials. Lancaster: Technomic Publishing; 1999.
- [3] Wang CM. Vibration frequencies of simply-supported polygonal sandwich plates via Kirchhoff solutions. *J Sound Vibrat* 1996; 190(2): 250–5.
- [4] Reddy JN. Mechanics of laminated composite plates: theory and analysis. Boca Raton (FL): CRC Press; 1997.
- [5] Meunier M, Sheno RA. Dynamic analysis of composite sandwich plates with damping modeled using high-order shear deformation theory. *Comp Struct* 2001; 54: 243–54.
- [6] Lee LJ, Fan YJ. Bending and vibration analysis of composite sandwich plates. *Comput Struct* 1996; 60(1): 103–12.
- [7] Monforton GR, Schmit LA Jr. Finite element analysis of sandwich plates and cylindrical shells with laminate faces. In: Proceedings of the 2nd conference on matrix methods in structural mechanics, Wright-Patterson Air Force Base, Ohio, 15–17 October 1969. p. 573–616.
- [8] Zhou HB, Li GY. Free vibration analysis of sandwich plates with laminated faces using spline finite point method. *Comput Struct* 1996; 2: 257–63.
- [9] T. Kant, K. Swaminathan, Free vibration of isotropic, orthotropic, and multilayer plates based on higher order refined theories, *Journal of Sound and Vibration* 241 (2) (2001) 319–327.
- [10] T. Kant, K. Swaminathan, Analytical solutions for free vibration of laminated composite and sandwich plates based on a higher order refined theory, *Composite Structures* 53 (2001) 73–85.
- [11] S. Kapuria, P.C. Dumir, N.K. Jain, Assessment of zig-zag theory for static loading, buckling, free and forced response of composite and sandwich beams, *Composite Structures* 64 (2004) 317–327.
- [12] Y. Han and J. Elliott, *Comput. Mater. Sci.*, 39, 315 (2007).
- [13] R. Moradi-Dastjerdi, M. Foroutan, and A. Pourasghar, *Mater. Des.*, 44, 256 (2013).
- [14] K. Mehar and S.K. Panda, *IOP Conf. Ser. Mater. Sci. Eng.*, 115, 12014 (2016).
- [15] Reddy JN. Mechanics of laminated composite plates: theory and analysis. Boca Raton: CRC Press; 1997.
- [16] Y.S. Rao, R. YVKS, Theory of vibratory bending of unsymmetrical sandwich plates 25 (2) (1973) 213–225.
- [17] J. Yang, S. Kitipornchai, and K.M. Liew, *J. Mech. Mater. Struct.*, 3, 1977 (2008).
- [18] M.K. Pandit, B.N. Singh, and A.H. Sheikh, *Thin-Walled Struct.*, 46, 1183 (2008).
- [19] Z.X. Wang, and H.S. Shen, *Compos. B: Eng.*, 43, 411 (2012).
- [20] K.M. Liew, J. Wang, T.Y. Ng, and M.J. Tan, *J. Sound Vib.*, 276, 997 (2004).