

Design of Inward Limbs 3 RPS Manipulator for Machining Purpose and Kinematics Simulation Using ADAMS

Bibi Farouk Zulfiqar Ibrahim¹, Liu Ying²

¹ Tianjin University of Technology and Education, School of Mechanical Engineering,
No.1310, Dagu South Road, Hexi District, Tianjin P.R.C

² Professor, Tianjin University of Technology and Education, School of Mechanical Engineering,
No.1310, Dagu South Road, Hexi District, Tianjin P.R.C

Abstract: *The paper dealt with the 3-RPS manipulator that have inward limb structure to normal manipulator configuration, that is the three limbs are situated close to centre of the fixed based and open outward to support the platform, the kinematics analysis is discuss in detail and Adam software is used to show the orientation and position of the platform with respect to the limbs length and positions. The result is compared with derived kinematics equations.*

Keywords: Inward limb structure, singularity, rigidity/stiffness, working space

1. Introduction

Since the inception of high speed machining, parallel manipulators are playing important roles in the field. Various companies developed CNC machines which are capable of meeting the demand of the machining parameters, yet one field of important interest for the all work is parallel manipulator capability to meet the required criterion of the machine. As such many researchers make an immense contribution to the design and development in the field. The most important aspect required in high speed machining robots is ability to reach the specified working space and to be rigid in order to avoid any form of singularity and retain position of stiffness during the operation to avoid compromising any safety and machining data.

A parallel manipulator is a closed-loop mechanism where a moving platform is connected to the base by at least two serial kinematics chains (legs). The conventional Stewart Platform (SP) manipulator has six extensible legs and hence a very rigid kinematics structure [1].

Compared to serial kinematics manipulators, an SP has the desirable characteristics of high payload and rigidity. However, the drawback of an SP is a much limited working envelope, more complex direct kinematics and control algorithms, coupled problems of the position and orientation movements, as well as the precise spherical joints are difficult to manufacture at low cost.

Many researchers has came up with a new idea of reducing the 6 (SP) manipulator to a lower degree of freedom manipulator achieving the desired goals of 6 (SP). This reduction leads to a lot of advantages from an increase in the working space to manufacturing cost and control system complexity. But yet rigidity/stiffness of the manipulator is compromised, Some

3-DOF parallel manipulator architectures provide pure relative rotation of the mobile platform about a fixed point and are used as pointing devices, wrists of manipulators and orienting devices [7, 8]. Furthermore, Tsai [6] introduced a novel 3-DOF translational platform that is made up of only revolute joints. It performs pure translational motion and has a closed-form solution for the direct and inverse kinematics.

For the purpose of this research 3 RPS manipulator is adopted with inward configuration to normal manipulator limbs to study its flexibility of working space and ruled out the possibility of singularity as the base is small. At the same time a passive SPS limb is attached to the centre of both fixed and moving platform for affirmation of stiffness. This also gives the platform the ability to translate in one axis and rotate in two axes. The work is categorized into four parts. The first part touches the manipulator configuration, then kinematics analysis, result and the last but not the least is conclusion

2. Proposed Mechanism

A sketch of the 3-RPS is given in Fig. 1. The platform and base are connected by three limbs which have the prismatic joints as extensible joints. It can be seen from Fig1. that the spherical joint connected the moving platform to the limb and also revolute joints connected the base to the limb, respectively.

Points **A** and **B** are geometrical centers of the base and moving platform, Points **a** is the distance from the geometrical centre of the base to the point of connection with the limb likewise point **b** is the distance from moving platform centre to spherical joint as in figure 2.

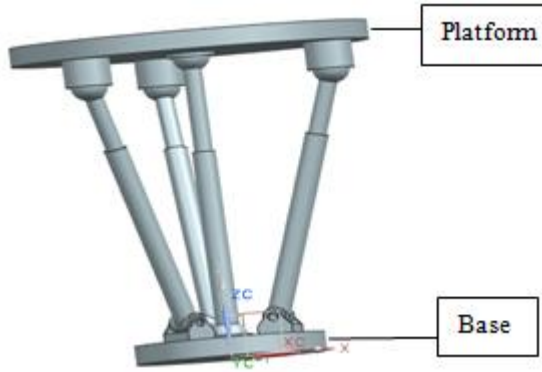

Figure 1

Linear motion of the required velocity and acceleration can be achieved either by using linear electromotor or rotary electromotor

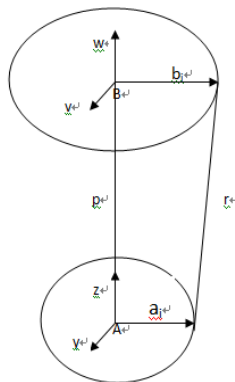

Figure 2

3. Kinematics Analysis

For the inverse kinematics problem, the position vector p and the rotation matrix aR_b of frame B with respect to A are given and the limb length r_i , $i = 1,2,3$ are to be found. Consider the Platform in figure 2

The length i^{th} of the leg is given by $r_i = p + {}^aR_b \cdot b_i - a_i$(1)

From Figure 3, the location of the i^{th} attachment point (b_i) on the moving platform can be found (Equation 2a). b_i and a_i are the radius of the moving platform and fixed base, respectively. $b_i = [b_{ix}, b_{iy}, b_{iz}]^T$, $a_i = [a_{ix}, a_{iy}, a_{iz}]^T$

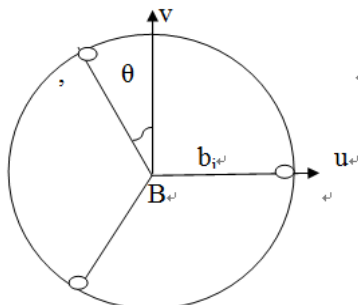

Figure 3

$$\left. \begin{aligned} i=1,2,3 \\ b_1 &= [b_1, 0, 0]^T \\ b_2 &= [-b_2 \cos \theta, b_2 \sin \theta, 0]^T \\ b_3 &= [-b_3 \cos \theta, -b_3 \sin \theta, 0]^T \end{aligned} \right\} \dots (2a)$$

By using the same approach, the location of the i^{th} attachment

point (a_i) on the base platform can be also obtained .Equation 2b.

$$\left. \begin{aligned} a_1 &= [a_1, 0, 0]^T \\ a_2 &= [-a_2 \cos \theta, a_2 \sin \theta, 0]^T \\ a_3 &= [-a_3 \cos \theta, -a_3 \sin \theta, 0]^T \end{aligned} \right\} \dots (2b)$$

Where the rotation matrix aR_b is;

$$\begin{bmatrix} \cos \beta \cos \gamma & \cos \gamma \sin \beta \sin \alpha - \cos \alpha \sin \gamma & \sin \alpha \sin \gamma + \cos \alpha \cos \gamma \sin \beta \\ \cos \beta \sin \gamma & \cos \alpha \cos \gamma + \sin \alpha \sin \beta \sin \gamma & \cos \alpha \sin \beta \sin \gamma - \cos \gamma \sin \alpha \\ -\sin \beta & \cos \beta \sin \alpha & \cos \alpha \cos \beta \end{bmatrix} \dots (2c)$$

$$P = [p_x \ p_y \ p_z]^T \dots (2d)$$

The length of the i^{th} limb is obtained by taking the dot product of the vector r_i by its self.

$$\left. \begin{aligned} r_i^2 &= [P + {}^aR_b \cdot b_i - a_i]^T [P + {}^aR_b \cdot b_i - a_i] \quad \text{for } i=1,2,3 \dots (2e) \\ r_i^2 &= (p_x - a_{xi} + b_{xi} u_x + b_{yi} v_x)^2 + (p_y - a_{yi} + b_{xi} u_y + b_{yi} v_y)^2 + (p_z + b_{xi} u_z + b_{yi} v_z)^2 \dots (2f) \end{aligned} \right\}$$

Inserting equation (2a) and (2b) into (2f) and writing the equation for each limb, $i = 1,2,3$ yield

$$d_1^2 = p_x^2 + p_y^2 + p_z^2 + a_1^2 + b_1^2 + k_1 \dots (2h)$$

Where

$$k_1 = 2b_1 \cos \beta (p_x \cos \gamma + p_y \sin \gamma) - 2a_1 b_1 \cos \beta \cos \gamma - 2p_z \sin \beta$$

$$d_2^2 = p_x^2 + p_y^2 + p_z^2 + a_2^2 + b_2^2 + k_2 \dots (2i)$$

Where

$$k_2 = 2a_2(p_x \cos \theta + p_y \sin \theta) + 2b_2 \cos \theta \cos \beta (p_x \cos \gamma + p_y \sin \gamma) + 2b_2 \sin \theta \sin \alpha \sin \beta (p_x \cos \gamma + p_y \sin \gamma) - 2b_2 \sin \theta \cos \alpha (p_x \sin \gamma - p_y \cos \gamma) + 2a_2 b_2 \cos \theta \cos \beta (\cos(\theta - \gamma)) + 2a_2 b_2 \sin \theta \sin \alpha \sin \beta (\cos(\theta + \gamma)) - 2a_2 b_2 \sin \theta \cos \alpha (\sin(\gamma - \theta)) + 2p_z b_2 \sin \theta (\cos \beta \sin \alpha) + 4b_2^2 \cos \theta \sin \theta (\cos \beta \sin \alpha \sin \beta)$$

$$d_3^2 = p_x^2 + p_y^2 + p_z^2 + a_3^2 + b_3^2 + k_3 \dots (2j)$$

where

$$k_3 = 2a_3(p_x \cos \theta + p_y \sin \theta) - 2b_3 \cos \theta \cos \beta (p_x \cos \gamma + p_y \sin \gamma) - 2b_3 \sin \theta \sin \alpha \sin \beta (p_x \cos \gamma + p_y \sin \gamma) + 2b_3 \sin \theta \cos \alpha (p_x \sin \gamma - p_y \cos \gamma) + 2a_3 b_3 \cos \theta \cos \beta (\cos(\theta - \gamma)) - 2a_3 b_3 \sin \theta \sin \alpha \sin \beta (\cos(\theta - \gamma)) - 2a_3 b_3 \sin \theta \cos \alpha (\sin(\gamma - \theta)) + 2p_z b_3 \sin \theta (\cos \beta \sin \alpha)$$

These 3 equations for $i=1$ to 3 give the lengths of the 3 legs to achieve the desired position and attitude of the platform.

The easiest way of finding the revolute joint angle and the platform position given the limb length is by resolving the structure into vector diagram of limb stroke as shown below.

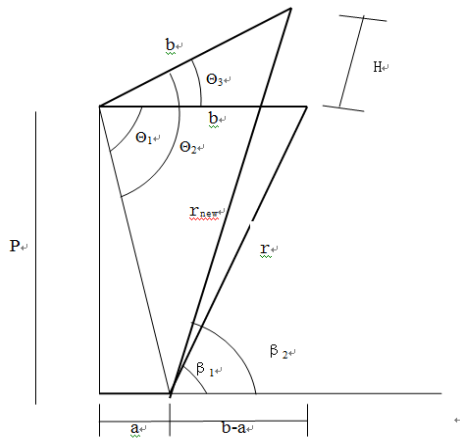

Figure 4: vector diagram for single limb stroke

Given the value of base and platform radii (a and b), height P and the change in limb distance H, all the remaining platform parameters can be determine effectively using sine or cosine rule.

4. Manipulator synthesis

The manipulator synthesis is carried out in UG modeling software with the following parameters

Table 1

Base radius (mm)	40
Manipulator radius (mm)	75
Limb length from the center line of the R joint to centre of the S joint (mm)	136
Distance between the two centers of the manipulator and the base (mm)	152

5. Result

Given the length of the limbs the positions and the orientation of the platform can be computed that's to say $q=[x \ y \ z \ \alpha \ \beta \ \gamma]^T$. Step function is used for the simulation and each limb is sign its own equation as follows.

- a) step(time, 0,0,0.1,0.1)-step(time, 0,0,0.2,0.1)
 - b) step(time, 0,0,0.2,0.1)-step(time, 0,0,0.4,0.1)
 - c) step(time, 0,0,0.3,0.1)-step(time, 0,0,0.6,0.1)
- for a single complete stroke and retract of each limb with a lag in time from limb one through limb three, a true picture of the platform posture at different times is shown below in three different period.



Figure 5a



Figure 5b



Figure 5c

Care has even observed for setting the limbs stroke length with time to avoid singularities. Given the parameters in table 1, when only the first limb in the mechanism is simulated with an increment of 50mm i.e. from the length of 136mm to 185mm, platform orientation angles $\theta_1, \theta_2, \theta_3$, is calculated as follows

$$\theta_1 = \cos^{-1} \frac{a}{(\sqrt{a^2 + p^2})} = 75.2564 \text{deg}$$

$$\theta_2 = \cos^{-1} \left(\frac{b^2 + a^2 + p^2 - r_{new}^2}{2 \times b \times (\sqrt{a^2 + p^2})} \right) = 99.51178 \text{deg}$$

$$\theta_3 = \theta_2 - \theta_1 = 24.2554 \text{deg}$$

Looking at the graph one and two, from the first graph one can figure out the length increment of 50mm in 1s. Tracing out the same time in graph two, the orientation angle (θ_3) of the platform can be know. This almost tallies with the calculated value of (θ_3).

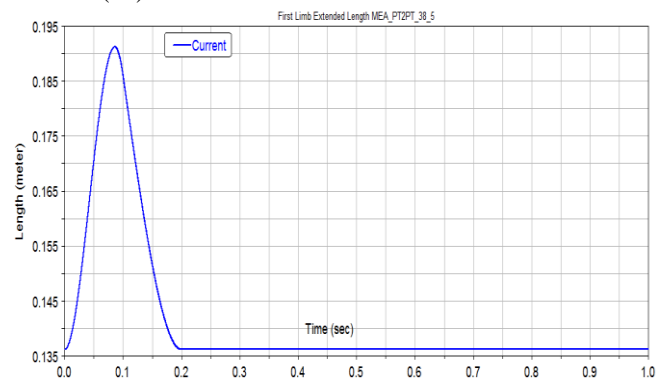

Graph 1: Limb1 stroke length

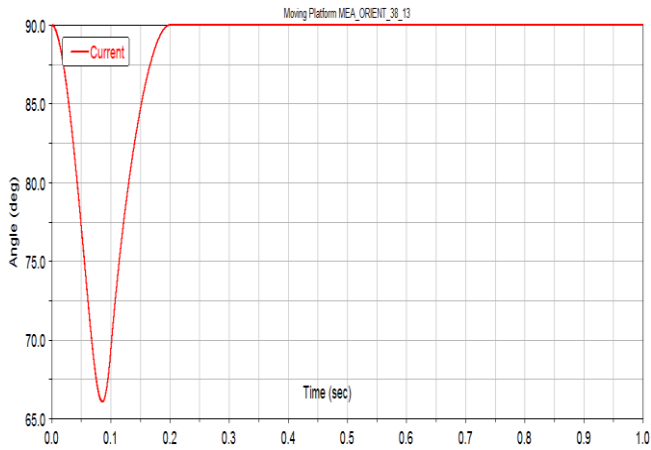

Graph 2: Euler Angles (third rotation) of Moving Platform

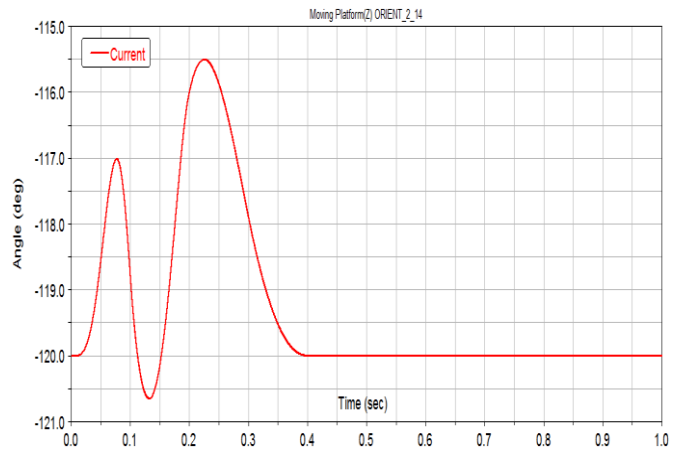

Graph 5: Euler Angles (first rotation) of Moving Platform

Also the platform orientation can be obtained from graph 3 to 7 as shown below, when both the limbs are active at given specified time i.e. at certain posture

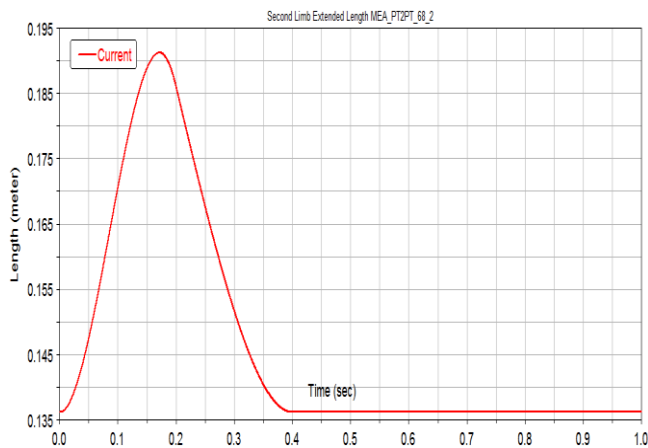

Graph 3: Limb2 stroke length

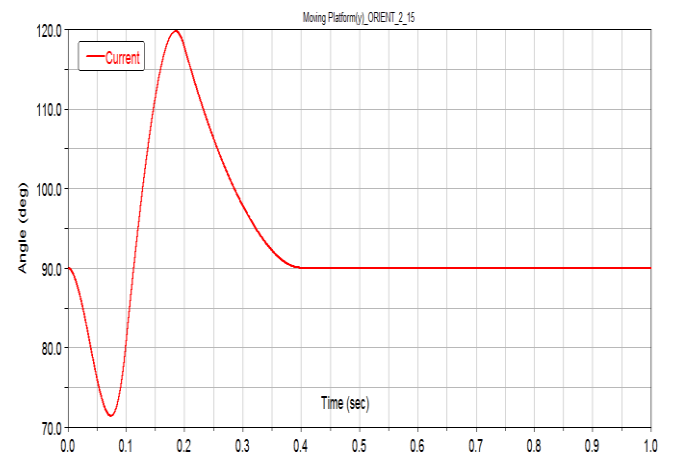

Graph 6: Euler Angles (second rotation) of Moving Platform

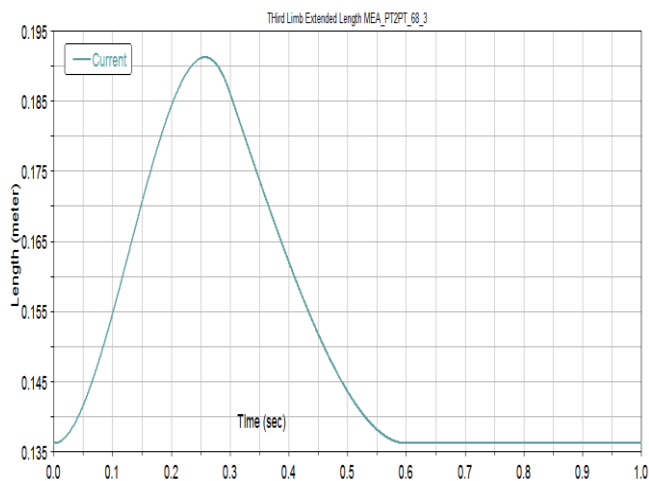

Graph 4: Limb2 stroke length

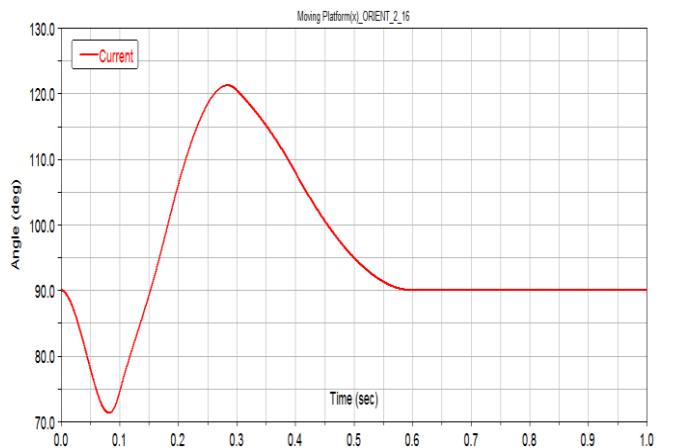

Graph 7: Euler Angles (third rotation) of Moving Platform

Graph 8 to 11 below shows the position length with time of the prismatic joints which was then transferred to the position of the platform. A trace can be follow of the limbs position in any axis in required time to obtain the platform position at that axis in that exact time.

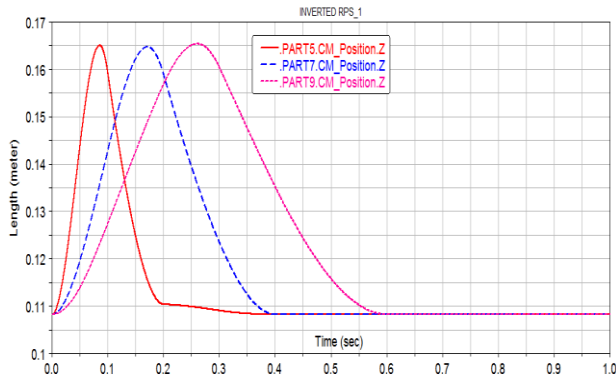

Graph 8: Limbs Positions in Z axis

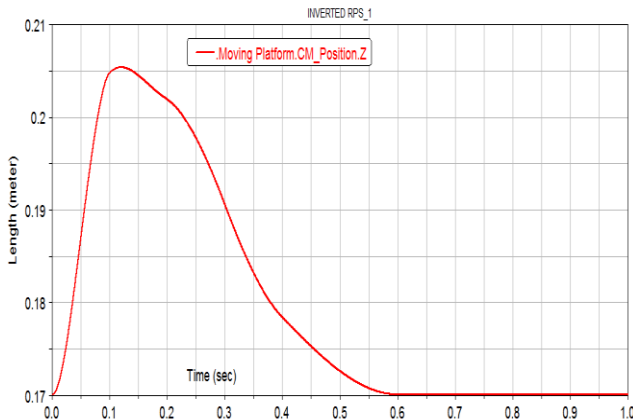

Graph 9: Moving Platform Positions in Z axis

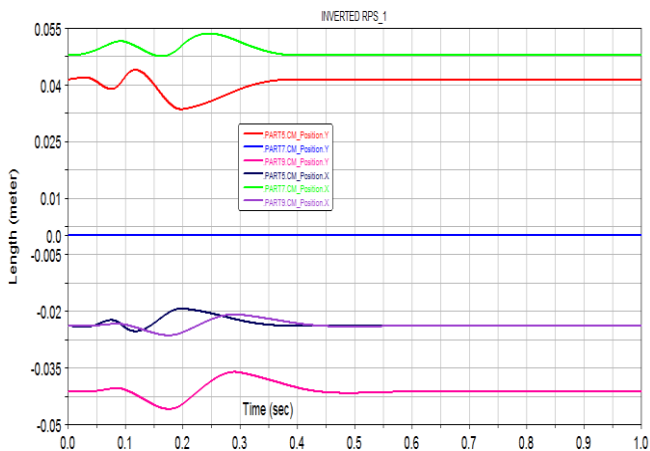

Graph 10: Limbs Positions in X and Y axes

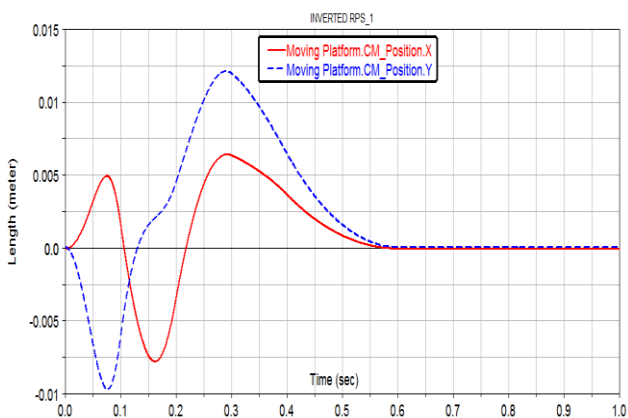

Graph 11: Moving Platform Positions in X and Y axes

6. Conclusion

The inward platform have been studied, and the model where simulated with ADAMS package. Analytical orientation of the platform is close to the simulated results, hence the platform have a good accuracy and can be used for what so ever machining operation. It's also found out that when the radius of the platform increase the orientation angle decrease. This is left to the designer choice for the application intended to perform.

References

- [1] Arockia Selvakumar. A, R. Sivaramakrishnan and K. Kalaichelvan (2010), Forward Kinematics and Dimensional Synthesis of Tripod and Triglide Parallel Manipulator, IJAET/Vol.I/ Issue III/Oct.-Dec.,2010/54-64
- [2] C.C. Ng, S.K. Ong and A.Y.C. Nee Design and Development Of 3-DOF Modular Micro Parallel Kinematic Manipulator
- [3] Tonshoff H.K, Grendel R., kaak R. (1999), Parallel Kinematic Machines- Theoretical Aspects and Industrial Requirements, Springer, Berlin, pp. 365 – 376.
- [4] HAO Qi 1, 2 , GUAN Liwen 1, , WANG Jinsong 1 , and WANG Liping (March , 2009) Dynamic Feedforward Control of A Novel 3PSP 3DOF Parallel Manipulator DOI: 10.3901/CJME.2009.03.
- [5] L.W. Tsai, G.C. Walsh, R.E. Stamper, 1996, “Kinematics of a Novel Three DOF Translational Platform”, Proceedings of the 1996 IEEE International Conference on Robotics and Automation Minneapolis, Minnesota – April 1996, pp. 3446-3451.
- [6] L.W. Tsai, 1999, “Robot Analysis: The Mechanics of Serial and Parallel Manipulators”, John Wiley & Sons, Inc., pp. 116-164.
- [7] L.W. Tsai, S. Joshi, 2002, “Kinematic Analysis of 3-DOF Position Mechanisms for Use in Hybrid Kinematic Machines”, Journal of Mechanical Design, Vol. 124, pp. 245–253.
- [8] Arockia Selvakumar. A, K.A. Anant , T. Lakshmi Narayanan, Dhandapani and Sivaramakrisnan. R (2009), Simulation and Kinematic analysis of Triglide parallel Manipulator, International Journal of Mechanics and Solids, September 2009, Vol 4, pp.127 –135