

# Hybrid Active Filter with Variable Conductance for Harmonic Suppression

Abdul Sattar Khan<sup>1</sup>, Prasanta Ku. Jena<sup>2</sup>

<sup>1</sup> Student: ME(Power Electronics)  
 Rungta College of Engineering & Technology(RCET) ,Bhilai, India,  
 sattark4@gmail.com

<sup>2</sup> Assistant Prof. : Department of Electrical Engineering  
 Rungta College of Engineering & Technology(RCET) ,Bhilai, India  
 , pkj.ped@gmail.com

**Abstract**— The tuned passive filter and the line inductance, causes unintentional series and/or parallel resonances, may result in severe harmonic distortion in the industrial power system. Here we present a paper in which hybrid active filter is used to suppress harmonic resonance and to reduce harmonic distortion. The proposed hybrid filter is operated as variable harmonic conductance according to the voltage total harmonic distortion; therefore, harmonic distortion can be reduced to an acceptable level in response to load change or parameter variation of the power system. Since the hybrid filter is composed of a seventh-tuned passive filter and an active filter in series connection, both DC voltage and kVA rating of the active filter are dramatically decreased compared with the pure shunt active filter. In real application, this feature is very attractive since the active power filter with fully power electronics is very expensive. A reasonable trade off between filtering performances and cost is to use the hybrid active filter. Design consideration is presented, and experimental results are provided to validate effectiveness of the proposed method. Furthermore, this paper discusses filtering performances on line impedance, line resistance, voltage unbalance, and capacitive filters.

**Keywords**— Harmonic resonance, hybrid active filter, industrial power system.

## 1. Introduction

Harmonic pollution is becoming increasingly serious due to extensive use of nonlinear loads, such as adjustable speed drives, uninterruptible power supply systems, battery charging system, etc. This equipment usually uses diode or thyristor rectifiers to realize power conversion because of lower component cost and less control complexity. However, the rectifiers will contribute a large amount of harmonic current flowing into the power system, and the resulting harmonic distortion may give rise to malfunction of sensitive equipment or interfering with communication systems in the vicinity of the harmonic sources.

Normally, tuned passive filters are deployed at the secondary side of the distribution transformer to provide low impedance for dominant harmonic current and correct power factor for inductive loads. However, due to parameter variations of passive filters, unintentional series and/or parallel resonances may occur between the passive filter and line inductance. The functionality of the passive filter may deteriorate, and excessive harmonic amplification may result. Thus, extra calibrating work must be consumed to maintain the filtering capability.

Various active filtering approaches have been presented to address the harmonic issues in the power system. The active filter intended for compensating harmonic current of nonlinear loads is the most popular one, but it may not be effective for suppressing harmonic resonances. Bhattacharya and Divan proposed a hybrid series active filter to isolate harmonics between the power system and the harmonic source. A so-called “active inductance” hybrid filter was presented to improve the performance of the passive filter. Fujita *et al.* Proposed a hybrid shunt active filter with filter-current detecting method to suppress the fifth harmonic resonance between the power system and a capacitor bank. A Hybrid filter in series with a capacitor bank by a coupling transformer was proposed to suppress the harmonic resonance and to compensate harmonic current. However, this method needs extra matching transformers or tuned passive filters to guarantee filtering functionality. Recently, a transformer less hybrid active filter was presented to compensate harmonic current and/or fundamental reactive current. Design consideration of the hybrid filter For current compensation has been extensively studied. A hybrid active filter with damping conductance was proposed to suppress harmonic voltage propagation in distributed power systems. Nevertheless, this method did not consider the resonance between the passive filter and the line inductance. The fixed conductance may deteriorate the damping performances. An antiresonance hybrid filter for delta-connected capacitor bank of power-factor-correction applications were presented. This circuit was limited to three single-phase inverters, and the filtering performance was not considered. In addition, the hybrid active filter was proposed for the unified power quality (PQ) conditioner to address PQ issues in the power distribution system. Several case studies of the hybrid active filter considering optimal voltage or current distortion were conducted in .

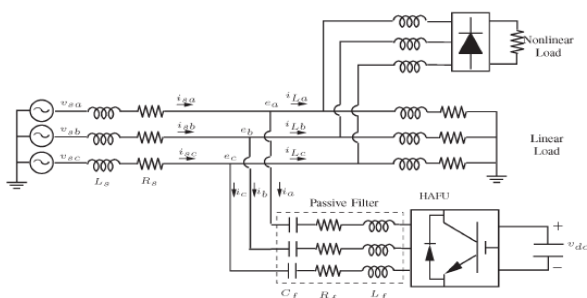

Figure 1: Circuit diagram of HAFU

In previous work, the authors have presented a transformerless hybrid active filter to suppress harmonic

resonances in the industrial power system. The hybrid filter is constructed by a seventh-tuned passive filter and an active filter in series connection. It operates as a variable conductance at harmonic frequencies according to the voltage THD, so that harmonic distortion can be reduced to an acceptable level in response to load change and power system variation. Since the series capacitor is responsible for sustaining the fundamental component of the grid voltage, the active filter is able to operate with a very low dc bus voltage, compared with the pure shunt active filter. Hence, both the rated kVA capacity and the switching ripples are reduced accordingly. Moreover, the proposed harmonic conductance is able to avoid overcurrent of the passive filter in the case of mistuning parameters. These features will benefit practical applications..

In this paper, we further present designing consideration of the hybrid filter. A prototype circuit of the hybrid filter based on 220-V/10-kVA system has been established to verify theoretic analysis, including steady-state behavior, transient response, and stability analysis. The filtering performance of the hybrid filter is discussed considering X/R ratio and magnified variations of line impedance. We also focus on filtering deterioration due to line resistance, voltage unbalance, and capacitive filters in the power system. In many cases, an active power filter is designed to compensate harmonic current produced by a specific nonlinear load, in such a way that it needs to measure the load current to be compensated. In this paper, the active filter is designed as a harmonic conductance to suppress both harmonic resonance and harmonic distortion by using inverter-side voltage and current measurements. Notice that it does not require current information of the nonlinear loads. Thus, this approach can be suitable in power distribution networks in which the loads may be distributed along a feeder. In addition, compensating fundamental reactive power due to unbalanced load is possible, but it is outside the scope of this paper.

## 2. Need Of Hybrid Active Filter

The main objective of the hybrid active filter such that the harmonics in the current waveform is reduced. The control algorithm has the following objectives :

- A. To suppress harmonic resonance.
- B. To control voltage injected by Active filter such that it compensate reactive power load current harmonics of the current designations.
- C. To improve passive filter performance

## 3. Operation Principle

Fig.1 shows a simplified circuit diagram considered in this paper, where  $LS$  represented the line inductance plus the leakage inductance of the transformer. The hybrid active filter unit (HAFU) is constructed by a seventh-tuned passive filter and a three-phase voltage source inverter in series connection. The passive filter  $L_f - C_f$  is intended for compensating harmonic current and reactive power. The inverter is designed to suppress harmonic resonances and

improve the filtering performances of the passive filter. Fig.2 shows the overall control block diagram of the HAFU, including harmonic loop, fundamental loop, current regulator, and conductance control. A detailed principle will be presented as follows.

### D. Harmonic Loop

To suppress harmonic resonances, the HAFU is proposed to operate as variable conductance at harmonic frequencies as follows:

$$i_h^* = G^* \cdot e_h \quad (1)$$

where  $i_h^*$  represents the harmonic current command. The conductance command  $G^*$  is a variable gain to provide damping for all harmonic frequencies. Harmonic voltage component  $e_h$  is obtained by using the so-called SRF transformation [9], where a phase-locked loop (PLL) is realized to determine the fundamental frequency of the power system. In the SRF, the fundamental component becomes a dc value, and other harmonic components are still ac values. Therefore, harmonic voltage component  $e_{qd,h}^e$  can be extracted from  $e_{qd}^e$  by using high pass filters. After transferring back to a three-phase system, the harmonic current command  $i_h^*$  is obtained by multiplying  $e_h$  and the conductance command  $G^*$ , as shown in (1).

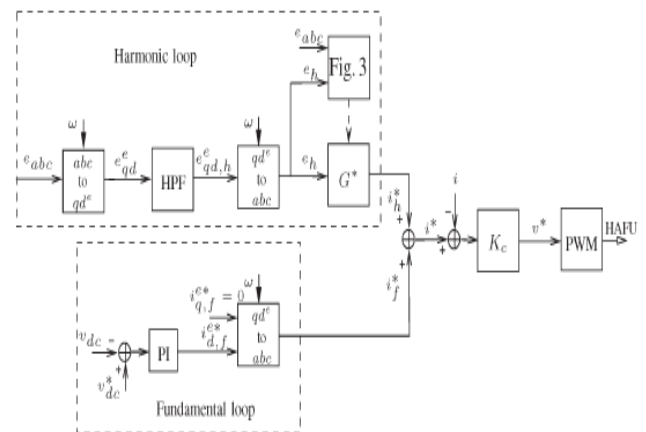

Figure 2: Control block diagram of HAFU

### E. Fundamental Loop

In this paper, the  $q$ -axis is aligned to  $a$ -phase voltage. Since the passive filter is capacitive at the fundamental frequency, the passive filter draws fundamental leading current from the grid, which is located on the  $d$ -axis. The proposed inverter produces a slight fundamental voltage on the  $d$ -axis, which is in phase with the fundamental leading current. Therefore, the control of DC bus voltage is able to be accomplished by exchanging real power to the grid. Thus, the current command is obtained by a proportional–integral (PI) controller. The fundamental current command in the three-phase system is generated after applying the inverse SRF transformation. Equation (2) shows the harmonic voltage drop on the passive filter due to the compensating current of the HAFU, where represents the maximum harmonic current of the active filter, and the voltage drop on filter resistance is neglected. As can be seen, a large filter capacitor results in the reduction of the required dc voltage. On the other hand, the filter capacitor determines reactive

power compensation of the passive filter at the fundamental frequency. Thus, the dc voltage can be determined based on this compromise. Note that the compensating current should be limited to ensure that the hybrid filter operates without undergoing saturation, i.e.,

$$v_{dc} = 2\sqrt{2} \sum_n \left| \frac{1}{j\omega_n C_f} + j\omega_n L_f \right| \cdot I_n$$

**F. Current Regulator**

The current command  $i^*$  is consisted of  $i_h^*$  and  $i_f^*$ . Based on the current command  $i^*$  and the measured current  $i$ , the voltage command  $v^*$  can be derived by using a proportional controller as follows:

$$v^* = K_c (i^* - i) \tag{3}$$

Where  $K_c$  is a proportional gain. According to the voltage command  $v^*$ , space-vector pulse width modulation (PWM) is employed to synthesize the required output voltage of the inverter. Fig.(c) shows the model of the current control. The computational delay of digital signal processing is equal to one sampling delay  $T$ , and PWM delay approximates to half sampling delay  $T/2$ . Hence, the proportional gain  $K_c$  can be simply evaluated from both open-loop and closed-loop gains for suitable stability margin and current tracking capability.

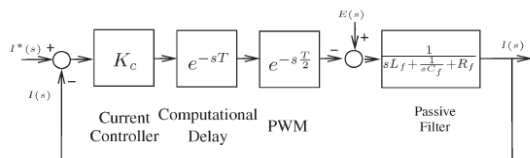

**Figure.3:** Closed loop model of current control

**G. Conductance Control**

Fig.4 shows the proposed conductance control. The harmonic conductance command is determined according to the voltage THD at the HAFU installation point. The voltage THD is approximately calculated by the control shown in Fig.4. Here, two low-pass filters (LPFs) with cutoff frequency = 20 Hz are realized to filter out ripple components. The error between the allowable and the measured THD is then fed into a PI controller to obtain the harmonic conductance command. The allowable distortion could be referred to the harmonic limit in IEEE std. 519-1992. Note that PI parameters need to be tuned for required response and stability. For example, the proportional gain can be tuned for transient behavior, and the integral gain is responsible for suppressing the steady-state error. The bandwidth should be lower than one-tenth of the cutoff frequency of the current loop to assure stable operation. This way, the HAFU is able to dynamically adjust to maintain harmonic distortion at an allowable level.

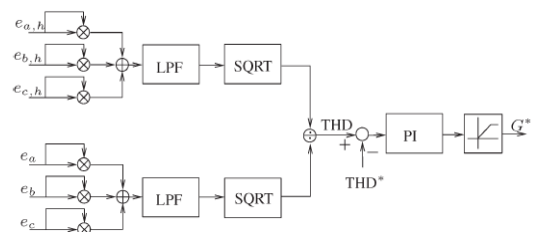

**Figure 4:** Conductance control block diagram

**4. Experimental Verification**

The filtering performance of the HAFU has been addressed by developing equivalent circuit models, in which both harmonic impedance and harmonic amplification are considered. The frequency characteristic of the passive filter is changed by the proposed harmonic conductance to avoid unintentional resonances. Here, we will concentrate on the damping performance with variation of line impedance, line resistance, and. Voltage unbalance and filter capacitors in the power system are also considered. The performance of the system with the proposed control strategy under different load conditions is discussed in detail in the following section. The proposed control strategy is simulated with a non-linear balanced load and the performance of the system is analyzed.

**Table 1:** Experimental Parameter

S. NO.	EXPERIMENTAL PARAMETER	
	SYSTEM PARAMETER	Value
1.	Source Voltage(L-L)	400 V
2.	Switching Frequency	20 KHz
3.	Source Inductance	5.3 mH
4.	Source Resistance	3.6Ω
5.	Passive filter	$L_f = 1.0mH, C_f = 150\mu F, Q_f = 20$

The proposed control strategy is simulated with a non-linear balanced load and the performance of the system is analyzed. The system data is given in Table-I. With the system parameters in table-I, the MATLAB SIMULINK results are presented in Fig. shows the load current which is nothing but the source current of phase- „a“ without any compensation. The THD of this current is shown in Fig.7 which is too high (28.04%) exceeding the IEEE standards. To filter the harmonics at first only the passive filter is connected and the source current waveform under this condition is shown in Fig.9. When both active and passive filters are connected together, the harmonics are still reduced and the source current is almost sinusoidal as shown in Fig.8. Now the THD of the current is very less (4.04%) and the harmonic analysis is shown in Fig.8. The use of active power filter increases the performance of the system and the overall power factor is also improved. In addition, the

characteristics of the passive filter are also improved and the 5<sup>th</sup> and 7<sup>th</sup> order harmonics are greatly reduced.

Time-domain simulations have been carried out to compare filtering performances between current compensating and voltage-damping hybrid active filters. In the current-compensating case, the load current is measured, and harmonic components are extracted by using synchronous reference frame transformations. In Fig.8, source current THDs and individual harmonic distortions are given for both light and heavy nonlinear load conditions. As shown, both methods are able to reduce source current distortion, and their filtering performances are similar. Further, by using the proposed approach, a small voltage value can provide even better filtering results, e.g., < 1.8%. In , experimental results of the current-compensating hybrid active filter show that source current distortion can be reduced from 28.03% to 4.40%, which are similar to the results of the proposed voltage-damping hybrid filter .

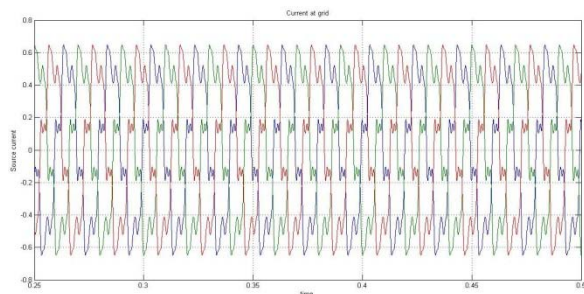

Figure 6: Source current without filter

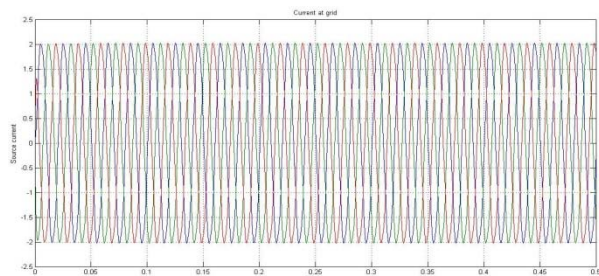

Figure 7: Source current with filter

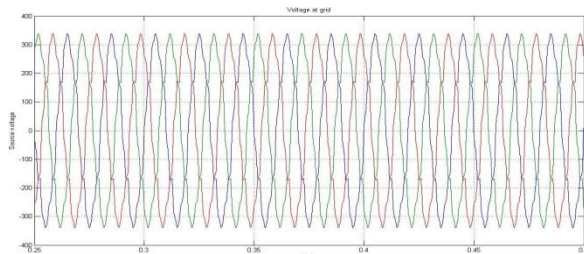

Figure 8: Source voltage without filter

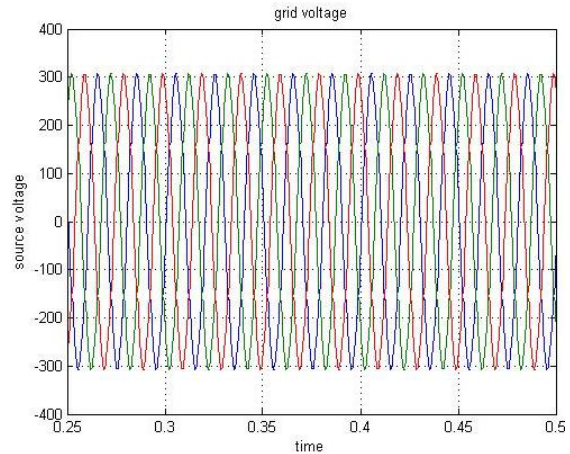

Figure 9: Source voltage with filter

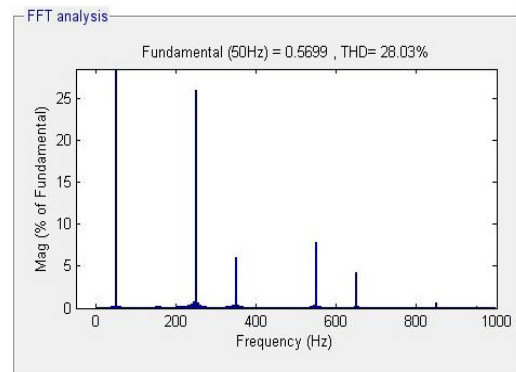

Figure 10: THD of source current without filter

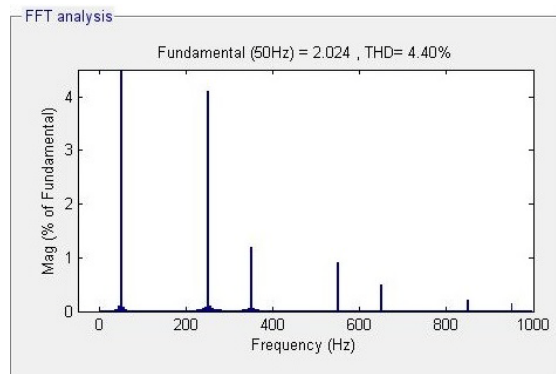

Figure 11: THD of source current with filter

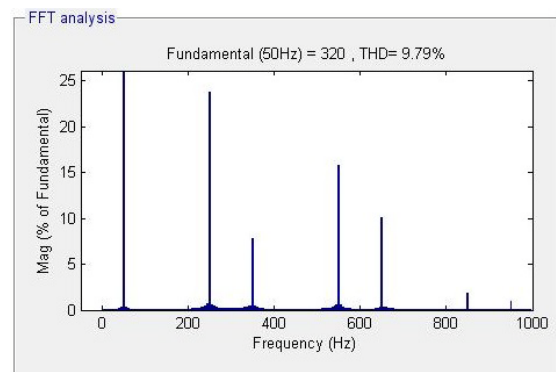

Figure 12 : THD of source voltage without filter

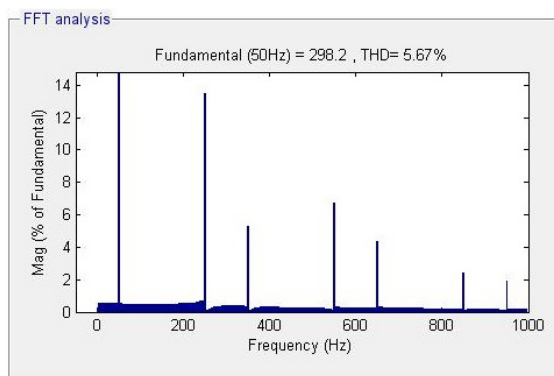

Figure 13 :THD of source voltage with filter

## 5. Conclusion

The demand for electric power is increasing at an exponential rate and at the same time the quality of power delivered became the most prominent issue in the power sector. Thus, the reduction of harmonics and improving the power factor of the system is of utmost important. In this project a solution to improve the electric power quality by the use of Hybrid Active Filter is discussed. From the study of Hybrid Active Filter for power quality improvement the following conclusions are drawn-

- Most of the load connected to the system are non-linear which are the major source of harmonics in the system
- The non-linear load draws non-linear current from the supply
- Thus the voltage at PCC is also non-linear affecting the performance of end user equipment
- To compensate the load harmonics a filter is connected at the PCC, which injects the compensating current.
- To achieve this a Hybrid Active filter in series with Passive Filter is used.
- The HAFU is controlled based on variable conductance control Theory to compensate the load harmonic.
- Simulation of the proposed control strategy shows the behavior of HAFU under different operating condition.
- The connection of HAFU improves the passive filter characteristics in addition to improve the system performance.
- The HAFU works well even with variable loads and improves the power factor of the system.

## Acknowledgment

I would like to thank my supervisor **Prasanta Kumar Jena**, Department of Electrical Engineering(RCET) for his immense support and enlightened guidance for my paper which I have developed as a M.E. IV semester student(RCET). I am very grateful for the inspiring discussions with all my faculties. Their valuable support and path-guiding suggestions have helped me to develop

Parthivi College of Engineering & Management, Bhilai, Chhattisgarh

this paper. I am thankful to **Mr. Prashant kumar Choudhary(H.O.D RCET)**, Electrical Department for giving thoughtful suggestions during my work.

I owe the greatest debt and special respectful thanks to, Dr. S.P. Dubey (Dean R&D), Mr. Ashish Sahu (ME Cordinator) Rungta College of Engineering and Technology, Bhilai for their inspiration and constant encouragement that enabled me to present my work in this form.

I would like to take this opportunity to express my thanks towards everyone in the computer Laboratory of the Rungta College of Engineering and Technology, Bhilai.

I specially thank my colleagues, batch mates, friends and family for their support and help that they offered me during the course of development of this paper.

## References

- [1] Yi tang, Poh Chiang Loh, Fook Hoong Choo “Generalized design of high performance shunt active power filter with output LCL filter,” *IEEE transactions on industrial electronics*, vol. 59, no. 3, March 2011.
- [2] Avik bhattacharya, Chandan Chakraborty,” Parallel-connected shunt hybrid active power filters operating at different switching frequencies for improved performance”, *IEEE transactions on industrial electronics*, vol. 59, no. 11, November 2012.
- [3] Wai-hei choi, chi-seng lam,” Analysis of dc-link voltage controls in three-phase four-wire hybrid active power filters”, *IEEE transactions on power electronics*, vol. 28, no. 5, May 2013
- [4] Pablo Acuna, Luis Moran, Marco Rivera, “Improved active power filter performance for renewable power generation systems”, *IEEE transactions on power electronics*, vol. 29, no. 2, February 2014.
- [5] Tzung-Lin Lee, Yen-Ching Wang, Jian-Cheng Li, and Josep M. Guerrero” Hybrid Active Filter With Variable Conductance for Harmonic Resonance Suppression in Industrial Power Systems, *IEEE TRANSACTIONS ON INDUSTRIAL ELECTRONICS*, VOL. 62, NO. 2, FEBRUARY 2015.
- [6] R. Inzunza and H. Akagi, “A 6.6-kV transformer less shunt hybrid active filter for installation on a power distribution system,” *IEEE Trans. Power Electron.*, vol. 20, no. 4, pp. 893–900, Jul. 2005.
- [7] T.-L. Lee, Y.-C. Wang, and J. Guerrero, “Resonant current regulation for transformer less hybrid active filter to suppress harmonic resonances in industrial power systems,” in *Proc. IEEE APEC Expo.*, 2010.
- [8] Y.-C. Wang and T.-L. Lee, “A control strategy of hybrid active filter to compensate unbalanced load in three-phase three-wire power system,” in *Proc. IEEE PEDG Syst.*, 2012, pp. 450–456.
- [9] ] R. H. Simpson, “Misapplication of power capacitors in distribution systems with nonlinear loads-three case histories,” *IEEE Trans. Ind. Appl.*, vol. 41, no. 1, pp. 134–143, Jan./Feb. 2005.

- [10] T. Dionise and V. Lorch, “Voltage distortion on an electrical distribution system,” *IEEE Ind. Appl. Mag.*, vol. 16, no. 2, pp. 48–55, Mar./Apr. 2010.
- [11] J. H. R. Enslin and P. J.M. Heskes, “Harmonic interaction between a large number of distributed power inverters and the distribution network,” *IEEE Trans. Power Electron.*, vol. 19, no. 6, pp. 1586–1593, Nov. 2004.
- [12] A. V. Jouanne and B. Banerjee, “Assessment of voltage unbalance,” *IEEE Trans. Power Del.*, vol. 16, no. 4, pp. 782–790, Oct. 2001.
- [13] P. Rodriguez *et al.*, “Multiresonant frequency-locked loop for grid synchronization of power converters under distorted grid conditions,” *IEEE Trans. Ind. Electron.*, vol. 58, no. 1, pp. 127–138, Jan. 2011
- [14] Website of Texas Instruments 2010. [Online]. Available: <http://www.ti.com/>
- [15] D. N. Zmood, D. G. Holmes, and G. H. Bode, “Frequency-domain analysis of three-phase linear current regulators,” *IEEE Trans. Ind. Appl.*, vol. 37, no. 2, pp. 601–610, Mar./Apr. 2001.
- [16] M. Castilla, J. Miret, J. Matas, L. G. De Vicuna, and J. M. Guerrero, “Linear current control scheme with series resonant harmonic compensator for single-phase grid-connected photovoltaic inverters,” *IEEE Trans. Ind. Electron.*, vol. 55, no. 7, pp. 2724–2733, Jul. 2008
- [17] Y. W. Li, “Control and resonance damping of voltage-source and currentsource converters with LC filters,” *IEEE Trans. Ind. Electron.*, vol. 56, no. 5, pp. 1511–1521, May 2009.
- [18] M. Castilla, J. Miret, J. Matas, L. G. De Vicuna, and J. M. Guerrero, “Linear current control scheme with series resonant harmonic compensator for single-phase grid-connected photovoltaic inverters,” *IEEE Trans. Ind. Electron.*, vol. 55, no. 7, pp. 2724–2733, Jul. 2008.
- [19] D. N. Zmood, D. G. Holmes, and G. H. Bode, “Frequency-domain analysis of three-phase linear current regulators,” *IEEE Trans. Ind. Appl.*, vol. 37, no. 2, pp. 601–610, Mar./Apr. 2001.